

PO Box 159
242 Fredonia Avenue
Fredonia, WI 53021
Phone: 262-692-9125
Fax: 262-692-2883



Administrator:
cjenkins@village.fredonia.wi.us
Clerk:
mjohnson@village.fredonia.wi.us
Treasurer:
mdepies@village.fredonia.wi.us

AGENDA

FREDONIA ARCHITECTURAL CONTROL BOARD MEETING

Wednesday, May 31, 2023 6:00PM

Fredonia Government Center - Board Room
242 Fredonia Avenue, Fredonia, Wisconsin

THE FOLLOWING BUSINESS WILL BE BEFORE THE ARCHITECTURAL CONTROL BOARD FOR INITIATION, DISCUSSION, CONSIDERATION, DELIBERATION AND POSSIBLE FORMAL ACTION

1. Call to order
2. Consent Agenda
 - a) Approve minutes of April 19, 2023 Architectural Control Board meeting.
3. Motion to Approve Privacy Fence at 216 N. Milwaukee St.
4. Adjournment

UPON REASONABLE NOTICE, efforts will be made to accommodate the needs of disabled individuals through appropriate aids and services. For additional information or to request this service, contact the Village Clerk at (262) 692-9125.

NOTICE IS HEREBY GIVEN that a majority of the Fredonia Village Board may attend this meeting in order to gather information about a subject over which they have decision-making responsibility.

**VILLAGE OF FREDONIA
ARCHITECTURAL CONTROL BOARD MEETING MINUTES
APRIL 19, 2023**

The Architectural Control Board meeting was called to order at 6:00 p.m. by Chair Dan Gehrke.

Board members present: Dan Gehrke, Jessica Franck, Damon Ward, and Tom Miller.

Board members absent: Bob Lallensack

Others present: Don Dohrwardt, Roger Kison and Melissa Depies.

Approve Minutes

Motion by Jessica Franck, seconded by Damon Ward, to approve the November 16, 2022 Architectural Control Board meeting minutes as presented. Motion carried.

Motion to approve siding project for Precision Floor & Décor, located at 200 Highland Drive

Tom Miller questioned if there was an ordinance that required commercial buildings to have brick on the front. Don Dohrwardt stated that he believed that this change pertained to new buildings in the industrial park.

Jessica Franck stated that this project is simply refreshing the existing building, which will improve the appearance and they should not be required to include brick.

Damon Ward stated that brick on the front of this building would not enhance the look.

Building permit fees were discussed as no permit had been taken out for this project. Roger Kison will be in touch with the building owners to get permit issued.

Motion by Damon Ward, seconded by Jessica Franck, to approve installation of new windows and siding at 200 Highland Drive. Motion carried.

General discussion/updates

Dan Gehrke stated that Dollar General has requested to remove three Box Elder trees on top of the berm on the south side of the building. The excavation has caused the roots to be exposed; therefore, the trees will most likely die in the near future. It was the consensus of the board that the trees should be removed.

Tom Miller suggested that Sippel Electric receive some sort of beautification award for all the work done on that building to promote beautification projects. Dan Gehrke stated that Sippel Electric has received the Business of the Month award.

Anderson Automotive property was discussed. The property is unsightly with many cars, trucks, campers and boats stored for long periods of time. Discussion included if there was anything the Village could do to enforce this property to be cleaned up as it is an unsightly image for the gateway to the Village.

Adjourn

Motion by Damon Ward, seconded by Tom Miller, to adjourn the meeting at 6:23 p.m. Motion carried.



Building Permit Application

John Derler, Building Inspector (262) 692-2039
 242 Fredonia Ave
 PO Box 159
 Fredonia, Wisconsin 53021
 (262) 692-9125
<https://www.fredoniawi.gov/>

Date Received	5/25/2023		
Permit Number			
Total Fee	\$50		
Arch Board Approval		Final Inspection	

Owner's Information

Owner's Name	Rick and Mikayla Fechter
Site Address	216 N Milwaukee St
City, State, Zip Code	Fredonia, WI 53021
Phone Number	262-391-8641/920-210-9970
Email	fechterrick@yahoo.com

Contractor's Information

Check if owner is contractor

Contractor's Name	
Address	
Phone Number	
Email	
License/Certification Number	

Project Type

Types of Buildings	Other Units	Miscellaneous
Residential/ Multi-Family	Heating/ Wood Burning	Demolition
Residential/Multi-Family	Appliances	Moving Buildings on Public Ways
Additions/Alterations	Air Conditioning	Erosion Control
Detached Garage/ Accessory	HVAC Distribution Systems	Sewer Hookup
Dwelling	Plan Review	Sidewalk & Driveway
Foundations & Footings	Residential Plan Review	Re-Inspection
Agricultural	Special Inspections & Reports	Failure to Obtain Permit
Sheds	WI State Seal	Failure to Call For Required
Pools	Occupancy Permit	Inspections
Decks	Park Fee	Work Not Ready For Inspection
<u>Fences</u>	Property Record Fee	Architectural Control Board
All other buildings	House Numbers	

Cautionary Statement to Owner Obtaining Permit

101.65(lr) of the Wisconsin Statutes requires municipalities that enforce the Uniform Dwelling Code to provide an owner who applies for a building permit with a statement advising the owner that: If the owner hires a contractor to perform work under the building permit and the contractor is not bonded or insured as required under s.101.654(2)(a), the following consequences might occur: (a) The owner may be held liable for any bodily injury to or death of others or for any damage to the property of others that arises out of the work performed under the building permit or that is caused by a negligence of the contractor that occurs in connection with the work performed under the building permit. (b) The owner may not be able to collect from the contractor damages for any loss sustained by the owner because of a violation by the contractor of the one and two family dwelling code or an ordinance enacted under sub.(1)(a) because of any bodily injury or death of others or damage to the property of others that arises out of the work performed under the building permit or because of any bodily injury to or death of others or damage to the property of others that is caused by any negligence by the contractor that occurs in connection with the work performed under the building permit. It is hereby agreed between the undersigned and the Village of Fredonia that all work performed as herein described, according to the plans and specifications herewith presented, shall be completed in strict compliance with the ordinances of the Village of Fredonia and all the laws of the State of Wisconsin. By signing this permit application, it is understood that a contract exists between the owner and the Village of Fredonia and guarantees the right to enter for the required inspections and investigations. Applicant is obligated to ensure final inspection is made.

Applicant Signature:	<i>Rick Fechter</i>	Date:	5/25/2023
Village Rep Signature:		Date:	



Materials List:

- White Vinyl 6x6 Fence Panels
- White Vinyl Fence Posts
- White Vinyl Fence Post Caps
- Fast 2K Deck Post Anchor Foam

Belmont Privacy Fence (6 x 6)

Installation Instructions

For SKU# 1728601, 1728701

Required:

- Philips Screwdriver
- Measuring Tape
- String Line, Stakes, Level
- PVC Vinyl Cement (Menards #172-4587)
- Concrete or Gravel

Optional:

- Power Drill with 1/8" Drill Bit
- Post Hole Digger
- Power Auger
- Safety Glasses

Installation Tips:

- Prior to construction, check with your regulatory agency for local code requirements
- Contact your utility company to locate and mark underground lines
- Careful planning and measurement of your fence project is essential, as moving posts after the concrete sets is extremely difficult
- It is highly recommended to measure the panels prior to setting your posts, not all panels are the same width (+/- 3/16")

Planning is Essential

- Consider soil conditions, slopes, utility locations and property lines when positioning posts.
- Run a string line to locate the fence line and establish the outside faces of your posts (See Fig 1.)
- Mark the centers of the post locations for your fence. The maximum on center distance between fence rail posts is 72".

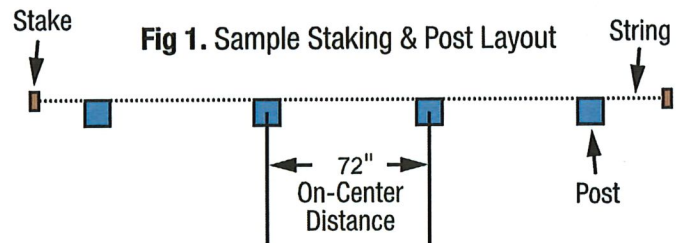

Item	Product Name	Qty
A	4" x 4" Vinyl Post	1
B	4" x 4" Post Cap	1
C	Rail Bracket	4
D	Screw	32
E	Fence Panel*	9
F	Top & Bottom Rail*	2

*These components are pre-assembled
 A,B,C & D included in Post Kit #'s 172-8602(White) & 172-8702(Tan) sold separately.
 E & F included in Fence Panel #'s 172-8601(White) & 172-8701(Tan).

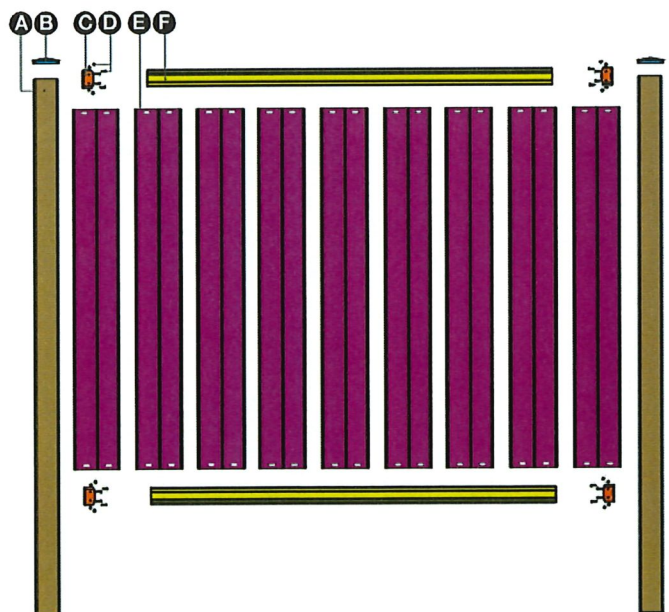

Setting Posts

1. Dig or auger post holes. The 4" x 5" Vinyl Posts require a **10" DIAMETER HOLE**, and must be at least **30" BELOW GRADE**. (See Fig 2.)
In frost regions, the post holes should be deep enough to extend below the frost line.
2. Mix concrete according to manufacturer's specifications. Fill the bottom of the hole to a level 24" from the surface.
3. Set the post into the hole, be sure it is square and in-line with your string layout.
4. Pour concrete around the post approximately 6" at a time. Tamp to eliminate air pockets, and continually check for level.
5. Before the concrete sets, sight down the fence line to be sure all posts align, and are at the same height. High posts can be driven deeper by placing a wooden block across the top and tapping down with a hammer. Allow concrete to set 24-48 hours.

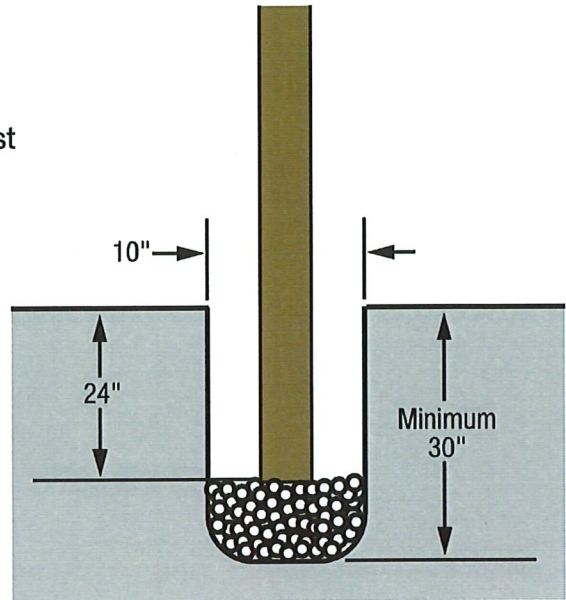

Fig 2. Setting Posts

Installing Fence Panel

1. Measure the distance between posts. If necessary, use a hack saw to cut Top and Bottom Rails (F) to fit. Be sure to cut equally from either end.
2. Use screws (D) to fasten Rail Bracket (C) to Top & Bottom Rails (F). (See Fig 3.)
3. Position the fence assembly between the posts. Align with adjacent fence panels or with the Top Rail slightly below the top of the vinyl posts. Screw all Rail Brackets (C) to the Vinyl Posts (A) using Screws (D). (See Fig 4.)
4. Affix the Post Cap (B) using PVC glue.

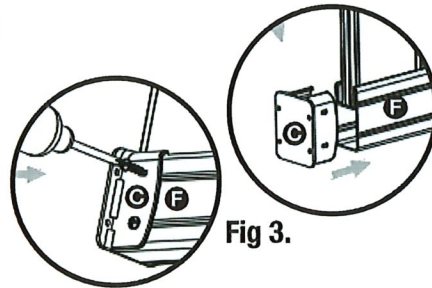
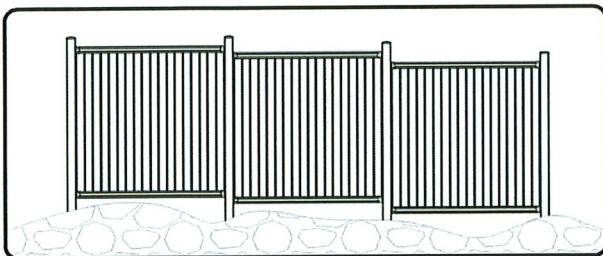

Fig 3.



NOTE: This fence type is designed to be installed on level between posts - it does not angle to follow slopes.

Use of this product must be in accordance with all local & zoning and/or building codes. Consumer assumes all risks and liability associated with the use of this product. For warranty details see the express written limited warranty for your product.

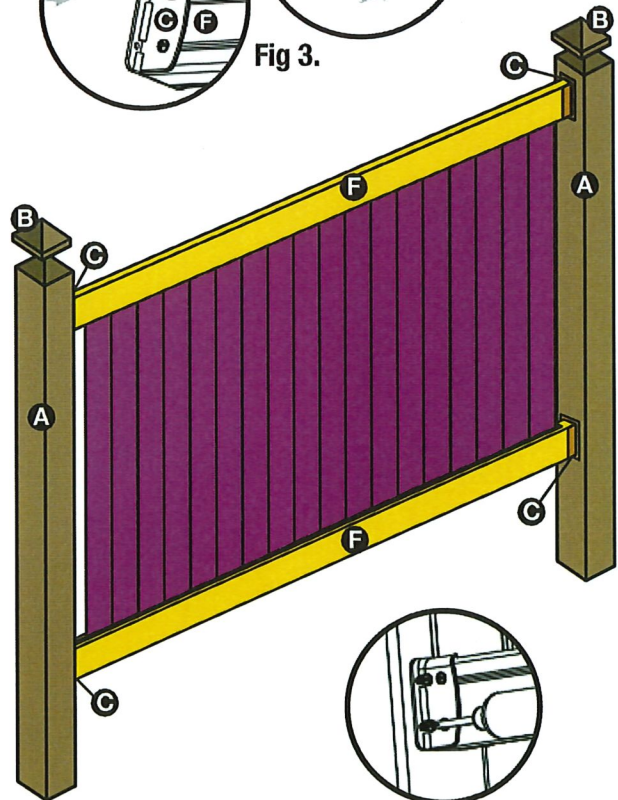

Fig 4.

I, Tina Scholz, the homeowner of 218 N. Milwaukee St.
Fredonia, WI, Consent to the homeowner's of 216 N.
Milwaukee St., to install a fence on our joined
property line.

Tina M Scholz
Signature

5-26-2023
Date

5/23/2023

I, Klarissa Elenteny own 212 N Milwaukee st and give Mikayla and Rick Fechter permission to build a fence on the property line.

Klarissa Elenteny